



## Power Quality Improvement Using Dynamic Voltage Restorer with Hysteresis Voltage Control Technique for Power Distribution System

Jitenkumar Parmar<sup>1</sup>, Niraj Danidhariya<sup>2</sup>, Deepakkumar Varu<sup>3</sup>

<sup>1,3</sup>M.E. [Power Electronics & Electrical Drives] Student, Department Of Electrical Engineering, Atmiya Institute of Technology & Science, Rajkot, Gujarat, India.

<sup>2</sup>Assistant Professor, Department Of Electrical Engineering, Atmiya Institute of Technology & Science, Rajkot, Gujarat, India.

**Abstract**—Power quality is one of main factor in present time. It has become important, with the introduction of power electronics devices, whose performance is very sensitive to the quality of power supply. Power quality problem is disturbance of voltage, current or frequency that results in a failure of end use equipment. One of the major problem here is the voltage sag. Sensitive industrial loads and utility distribution networks all suffer from various types of outages and service interruptions which may result in a significant financial loss. To improve the power quality, custom power devices are used. The device described in this work is DVR. This work present the analysis and simulation of a Dynamic Voltage Restorer using MATLAB and hysteresis voltage control technique is used for the control purpose. The role of DVR to compensate load voltage is investigated during the different fault conditions like voltage sag, single line to ground, double line to ground faults.

**Keywords**— Power Quality, Voltage Sag, DVR, Hysteresis Voltage Control.

### I. INTRODUCTION

Power Quality has become an important issue for electricity consumers at all levels of usage. The Power quality is “the provision of voltages and system design so that the user of electric Power can utilize electric energy from the distribution system successfully without interference or interruption”. The development of power electronic based equipment has a significant impact on quality of electric power supply. Distribution system locates the end of power system and is connected to the customer directly, so the power quality mainly depends on distribution system. The reason behind this is that the electrical distribution network failures account for about 90% of the average customer interruptions. In the earlier days, the major focus for power system reliability was on generation and transmission only as these more capital cost is involved in these. In addition their insufficiency can cause widespread catastrophic consequences for both society and its environment. But now a day’s distribution systems have more concern on reliability assessment.

Initially for the improvement of power quality or reliability of the system FACTS devices like STATCOM, SSSC, IPFC, UPFC etc. are introduced. These FACTS devices are designed for the transmission system. But now a day major concern is on the distribution system for the improvement of power quality, these devices are modified and known as custom power devices. The main custom power devices which are used in distribution system for power quality improvement are DSTATCOM, DVR, and AF etc. In this paper from the above custom power devices, DVR is used with Hysteresis voltage control strategy for improvement in the distribution system. Here voltage sag is examined. Also using Hysteresis voltage control scheme, voltage sag condition is eliminated by injecting voltage through injection transformer [1].

Compared to all other custom power devices DVR compensate the voltage dip, voltage swell, it can additionally include different features for example power factor correction and harmonics elimination. Also, it has capacity to manage the active power flow, its application includes lower cost, smaller size and fast dynamic response to the disturbance [2]

DVR has several advantages over other custom power devices described as below.

- DVR is the most efficient and effective modern custom power device used in power distribution network.[3]
- DVR is more minor in size and expenses less compared with the DSTATCOM.
- Other reasons include that the DVR has a higher energy capacity and lower costs compared to the SMES (Superconducting Magnetic Energy Storage) device.
- DVR costs less compared to the UPS.



establish an additional phase-lag/lead in the three-phase voltages. Differential current protection of the transformer, or short circuit current on the customer load side are only two examples of protection functions possibility.

### III. DVR CONTROL STRATEGY

A dynamic voltage restorer (DVR) is a custom power device using the device to improve the voltage sag condition. During the faulty condition the controller have key role to measure the difference between the actual source voltage and the load voltage and compensate the difference between this two signal by using the storage unit or from the DC side after filter. The basic implementation of hysteresis control is based on deriving the switching signals from the comparison of the voltage or current error with a fixed tolerance band [5]. This control is based on the comparison of the actual phase voltage or current with the tolerance band around the reference voltage or current associated with that phase [6].

- **Hysteresis Voltage Control Technique:**

Hysteresis Band Voltage control is used to control load voltage and determine switching signals for inverter switches. Fig.7 shows a full bridge inverter connected in series with a sensitive load. The inverter may be controlled in PWM methods.

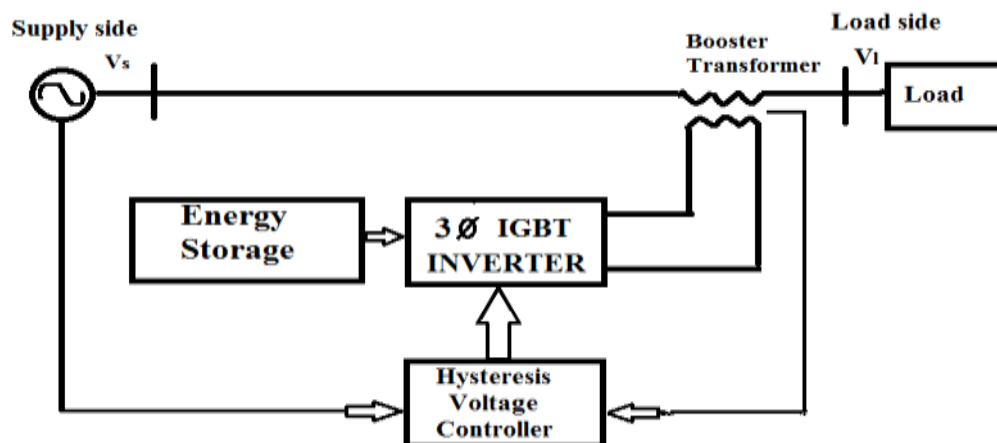

*Fig. 2: Structure of DVR with hysteresis voltage control technique*

This control method have two bands are to be consider the one is above and second is under the reference voltage. When the difference are to be consider between the reference and inverter voltage reaches to the upper or lower limit, at that particular time period the voltage is forced to decrease or increase as shown in Fig 8. In this method, the following relation is applied where HB and  $f_c$  are Hysteresis band and switching frequency, respectively [7].

$$T_1 + T_2 = T_c = 1/f_c.$$

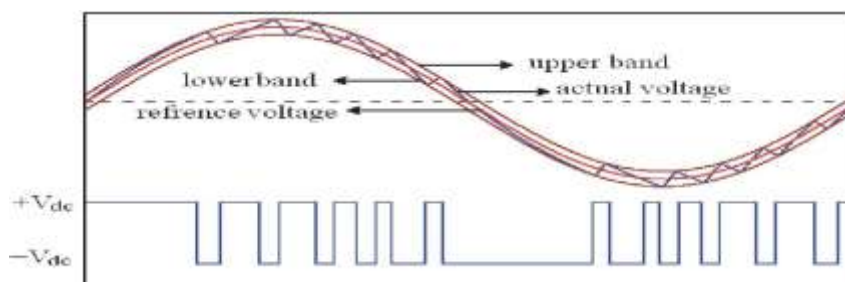

*Fig. 3: Output voltage with lower and higher bands*

The HB that has inverse proportional relation with switching frequency is defined as the Difference between  $V_H$  and  $V_L$  ( $HB = V_H - V_L$ ). The reference three-phase voltage signals generated is compared by the three-phase DVR output voltages to generate the switching pluses of the IGBT switches of thyristors.

#### IV. SIMULATION AND RESULTS OF DVR

The simulation parameter are shown below in the table-1. The closed loop simulation of DVR using hysteresis voltage control technique is shown below in fig-4. Various results of the Simulink model of DVR are shown in below fig-5, fig-6, fig-7, fig-8. figure-5 describes the output voltage with the voltage sag due to the 3- phase balanced fault. Figure-6 describes the output voltage after compensating the voltage sag. Figure-7 describes the line to line voltage with voltage sag. Figure-8 describes the output line to line voltage after compensating the voltage sag.

**Table-1: Simulation parameter**

COMPONENT	TYPE	RATING
VOLAGE SOURCE	3-PHASE	13 KV
TRANSFORMER 1	STEP UP(Y-Δ)	13 KV-115 KV
TRANSFORMER 2	STEP DOWN(Δ-Y)	115 KV-11 KV
LINE IMPEDENCE	SERIES RLC	R=1 Ω, L=1 mh
FAULT	3-PHASE BALANCED	R=0.66 Ω
LOAD	THREE PHASE RL	1 KW EACH

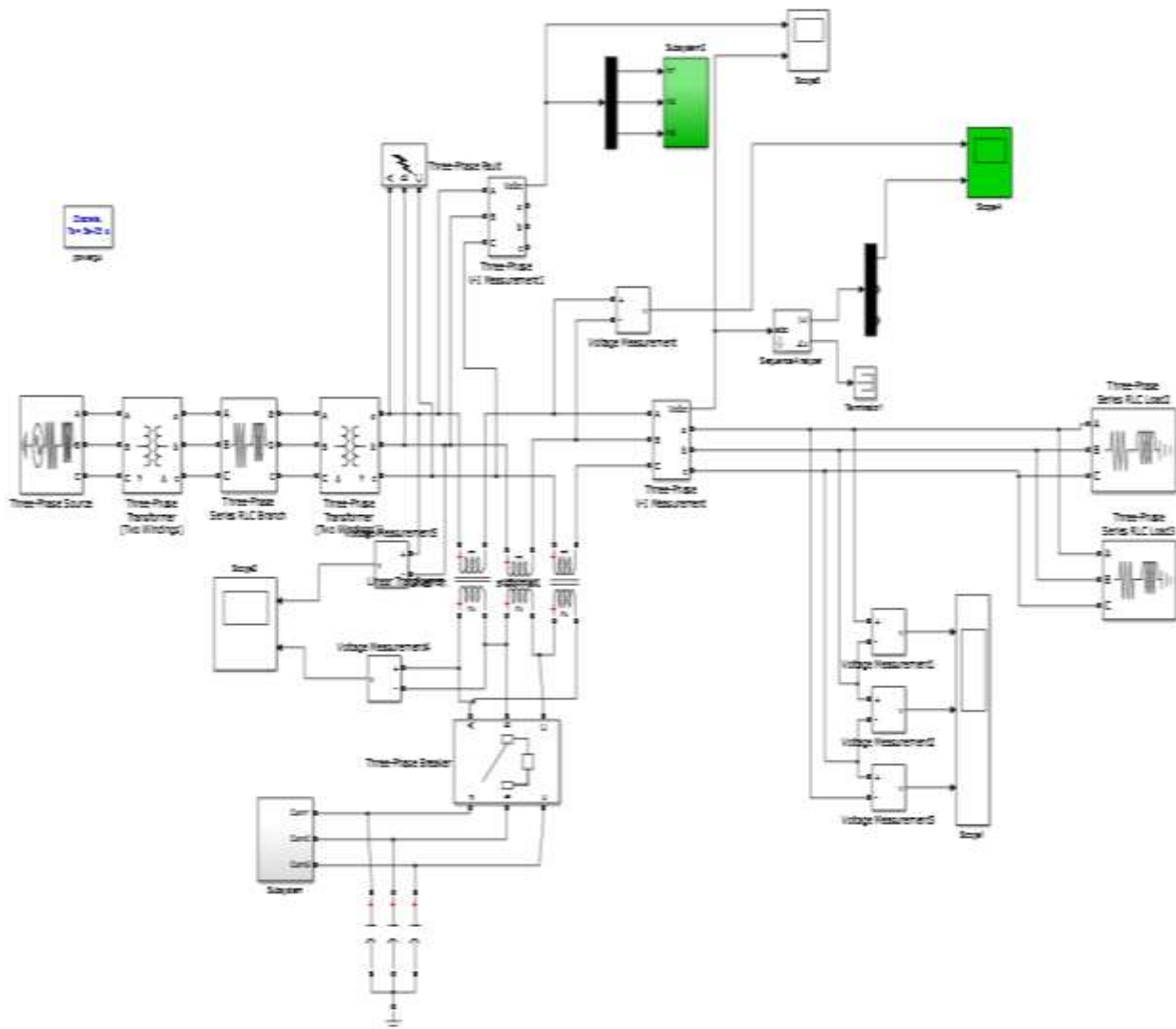

**Fig. 4: Simulink model of DVR with Hysteresis voltage control technique**

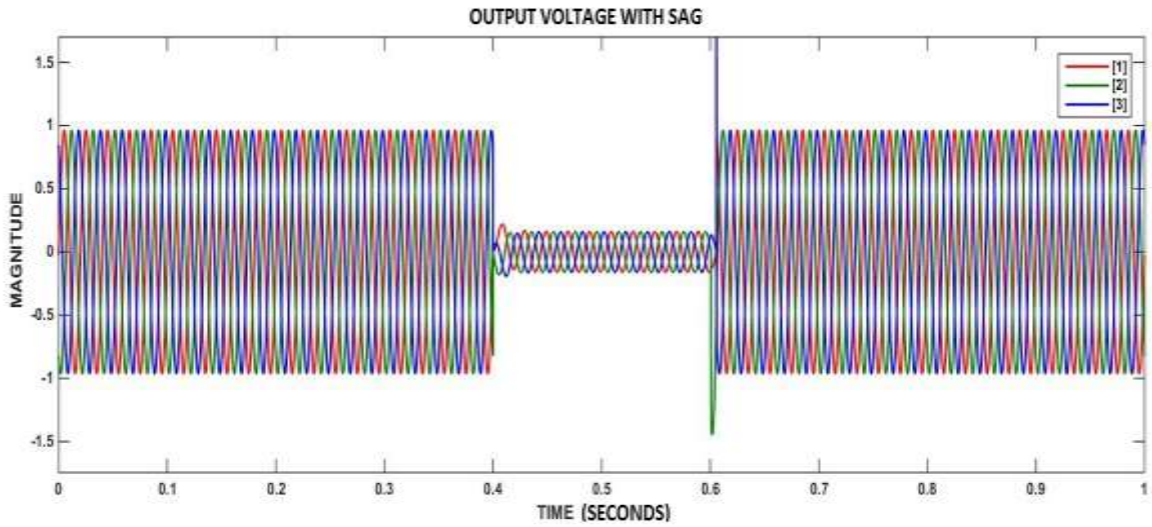

Fig. 5: Simulation results of output voltage with sag

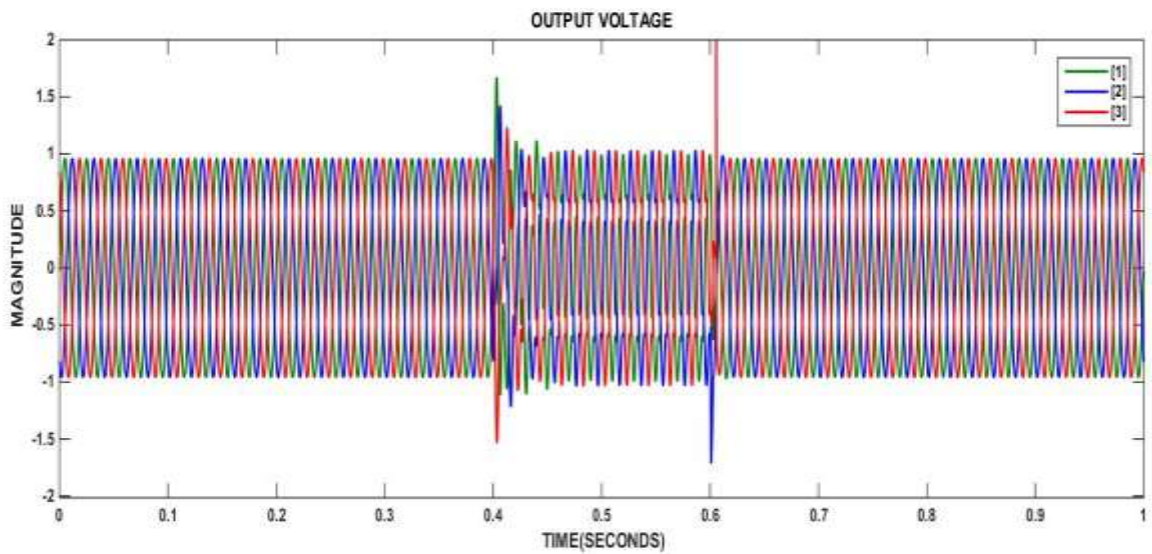

Fig. 6 : Simulation result of output voltage after compensating voltage sag

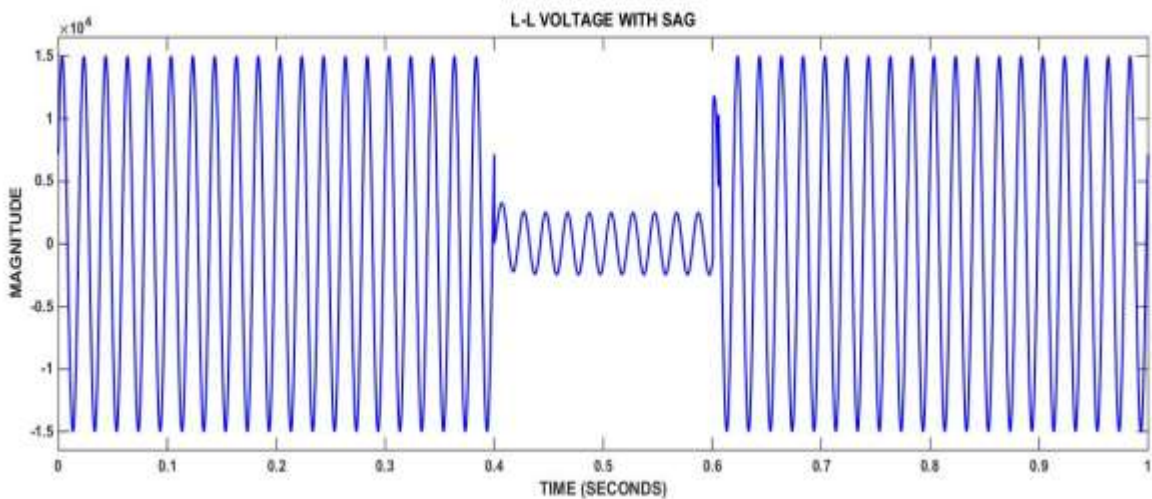
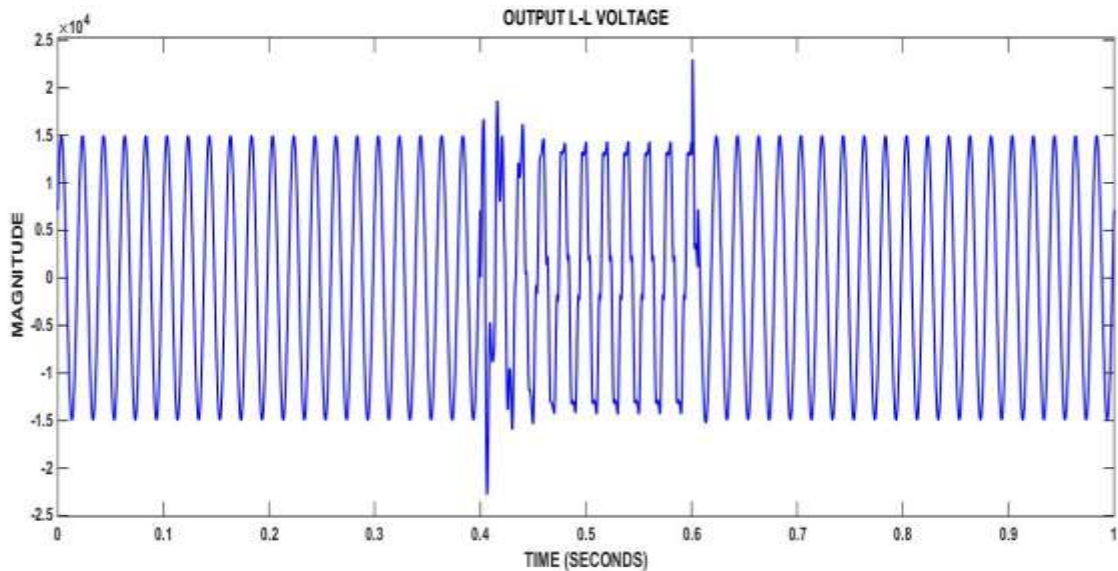

Fig. 7: Simulation result of supply line to line voltage with voltage sag



**Fig.8: Simulation result of output line to line voltage after compensating voltage sag**

## V. CONCLUSION

Transmission line system having problems with power quality like voltage sag is examined. To improve the power quality the DVR is introduced to system and the required voltage during fault condition is injected through the injection transformer of DVR by using hysteresis voltage control technique.

## REFERENCES

- [1] N.G. Hingorani, "Introducing Custom Power", IEEE Spectrum, vol. 32, pp. 41-48, 1995.
- [2] Arindam Ghosh, and Gerard Ledwich, "Compensation of Distribution System Voltage Using DVR", IEEE Transactions on Power Delivery, vol. 17, pp. 1030-1036, Oct. 2002. Ajay K. Damor, Prof. V. B. Babaria., "Voltage Sag Control Using DVR", National Conference on Recent Trends in Engineering and Technology, 13-14 May 2011.
- [3] Mahmoud A. El-Gammal, Amr Y. Abou-Ghazala, and Tarek I. El-Shennawy, "Dynamic Voltage Restorer (DVR) for Voltage Sag Mitigation", International Journal on Electrical Engineering and Informatics, pp. 1-10, Volume 3, Number 1, 2011.
- [4] H.P. Tiwari and Sunil Kumar Gupta "Dynamic Voltage Restorer against Voltage Sag" International Journal of Innovation, Management and Technology vol. 1, no. 3, pp. 232-237, 2010.
- [5] U. T. Patil, A. R. Thorat "Hysteresis Voltage Control Technique in Dynamic Voltage Restorer for Power Quality Improvement", 978-1-4673-6150-7/13/ ©2013 IEEE.
- [6] Ravilla Madhusudanl, G. Ramamohan Rao., "Modeling and Simulation of a Dynamic Voltage Restorer (DVR) for Power Quality Problems Voltage Sags and Swells", IEEE- International Conference on Advances in Engineering, Science and Management (ICAESM -2012), pp. 342-347 March 30, 31, 2012
- [7] Rosli Omar, N.A. Rahim and Marizan Sulaiman, "Dynamic Voltage Restorer Application for Power Quality Improvement in Electrical Distribution System: An Overview", Australian Journal of Basic and Applied Sciences, 5(12): pp. 379-396, 2011.
- [8] Ajay K. Damor, Prof. V. B. Babaria., "Voltage Sag Control Using DVR", National Conference on Recent Trends in Engineering and Technology, 13-14 May 2011.
- [9] S.Saravanan, M.Solaimanigandan, T.Tharaneetharan, V.Varunraj, S.Parthasarathy "Dynamic Voltage Restorer for Distribution System", International Journal of Engineering Research and Development e-ISSN: 2278-067X, p-ISSN: 2278-800X, www.ijerd.com Volume 7, Issue 1 (May 2013), PP. 14-24